



SR1620 THRU SR16100

16 A Schottky Barrier Rectifiers

Voltage Range 20 to 100 Volts
Current 16.0 Amperes

Features

- * Low forward voltage drop
- * High current capability
- * High reliability
- * High surge current capability
- * Epitaxial construction

Mechanical Data

- * Case: Molded plastic
- * Epoxy: UL 94V-0 rate flame retardant
- * Lead: Axial leads, solderable per MIL-STD-202, method 208 guaranteed
- * Polarity: Color band denotes cathode end
- * Mounting position: Any
- * Weight: 2.24 grams

TO-220

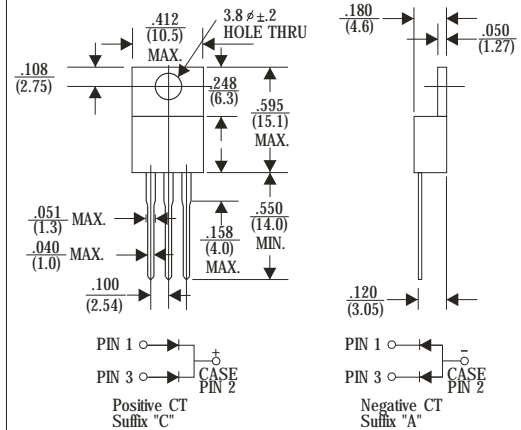

Dimensions in inches and (millimeters)

Maximum Ratings and Electrical Characteristics

Rating at 25°C ambient temperature unless otherwise specified Single phase, half wave, 60 Hz, resistive or inductive load. For capacitive load, derate current by 20%

Type Number	SR1620	SR1630	SR1640	SR1650	SR1660	SR1680	SR16100	Units
Maximum Recurrent Peak Reverse Voltage	20	30	40	50	60	80	100	v
Maximum RMS Voltage	14	21	28	35	42	56	70	v
Maximum DC Blocking Voltage	20	30	40	50	60	80	100	v
Maximum Average Forward Rectified Current See Fig. 1	16							A
Peak Forward Surge Current, 8.3 ms Single Half Sinewave - Superimposed on Rated Load method (JEDEC)	130				100			A
Maximum Instantaneous Forward Voltage At 8.0A	0.65			0.75		0.85		V
Maximum D.C. Reverse Current @ T _A =25°C	1.0							mA
At Rated DC Blocking Voltage @ T _A =100°C	100							mA
Typical Junction Capacitance (Note 1)	700			460		280		pF
Typical Thermal Resistance R _{JA} (Note 2)	3.5							°C/W
Operating Junction Temperature Range T _J	-50+125							°C
Storage Temperature Range T _{STG}	-65+150							°C

Notes:

1. Measured at 1MHz and applied reverse voltage of 4.0Volts D.C.
2. Thermal Resistance Junction to Case



SR1620 THRU SR16100

16 A Schottky Barrier Rectifiers

Voltage Range 20 to 100 Volts

Current 16.0 Amperes

RATING AND CHARACTERISTIC CURVES (SR1620 THRU SR16100)

FIG.1-TYPICAL FORWARD CURRENT DERATING CURVE

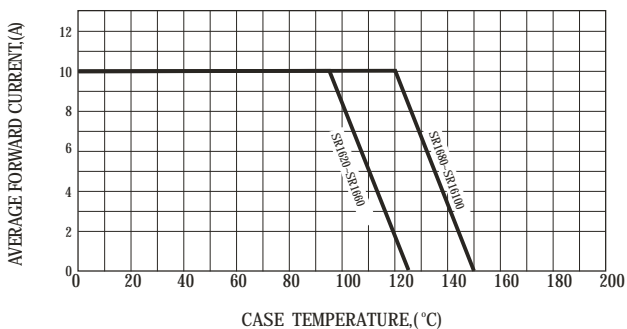

FIG.2-TYPICAL FORWARD CHARACTERISTICS

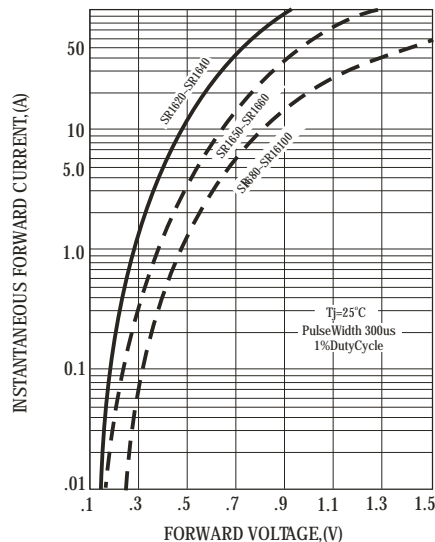

FIG.3-MAXIMUM NON-REPETITIVE FORWARD SURGE CURRENT

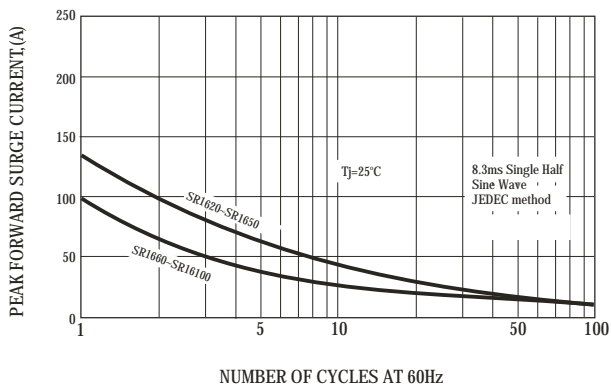

FIG.4-TYPICAL JUNCTION CAPACITANCE

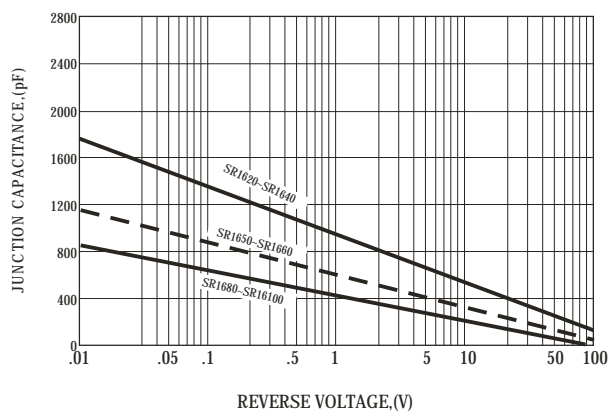

FIG.5 - TYPICAL REVERSE CHARACTERISTICS

